



# 8B45

## Frequency Input Modules

### Description

8B modules are an optimal solution for monitoring real-world process signals and providing high-level signals to a data acquisition system. Each 8B45 module isolates and conditions a frequency input signal and provides an analog voltage output.

The frequency input signal can be either a TTL level or zero crossing with as little as  $\pm 100\text{mV}$  amplitude. Input circuitry for each signal type has built-in hysteresis to prevent spurious noise from corrupting the module output. TTL signals are applied to the + and - terminals while zero crossing signals are applied to the +EXC and - terminals. Reference the block diagram below.

A 5V excitation is available for use with magnetic pick-up or contact closure type sensors. The excitation is available on the -EXC terminal with return on the - terminal.

A special input circuit on the 8B45 module provides protection against accidental connection of power-line voltages up to 240VAC. Clamp circuits on the I/O and power terminals protect against harmful transients.

Isolation is provided by optical coupling to suppress transmission of common mode spikes or surges. The module is powered from +5VDC,  $\pm 5\%$ .

The modules are designed for installation in Class I, Division 2 hazardous locations and have a high level of immunity to environmental noise.

### ► Features

- Accepts Frequency Input Signals 0 to 100kHz
- TTL or Zero-Crossing Signal Inputs
- High-Level Voltage Outputs
- 1500Vrms Isolation
- ANSI/IEEE C37.90.1 Transient Protection
- Input Protection to 240VAC Continuous
- 100dB CMR
- $\pm 0.10\%$  Accuracy
- $\pm 0.05\%$  Linearity
- Low Drift with Ambient Temperature
- CE Compliant
- C-UL-US Listed
- ATEX Compliance Pending
- Mix and Match Module Types on Backpanel

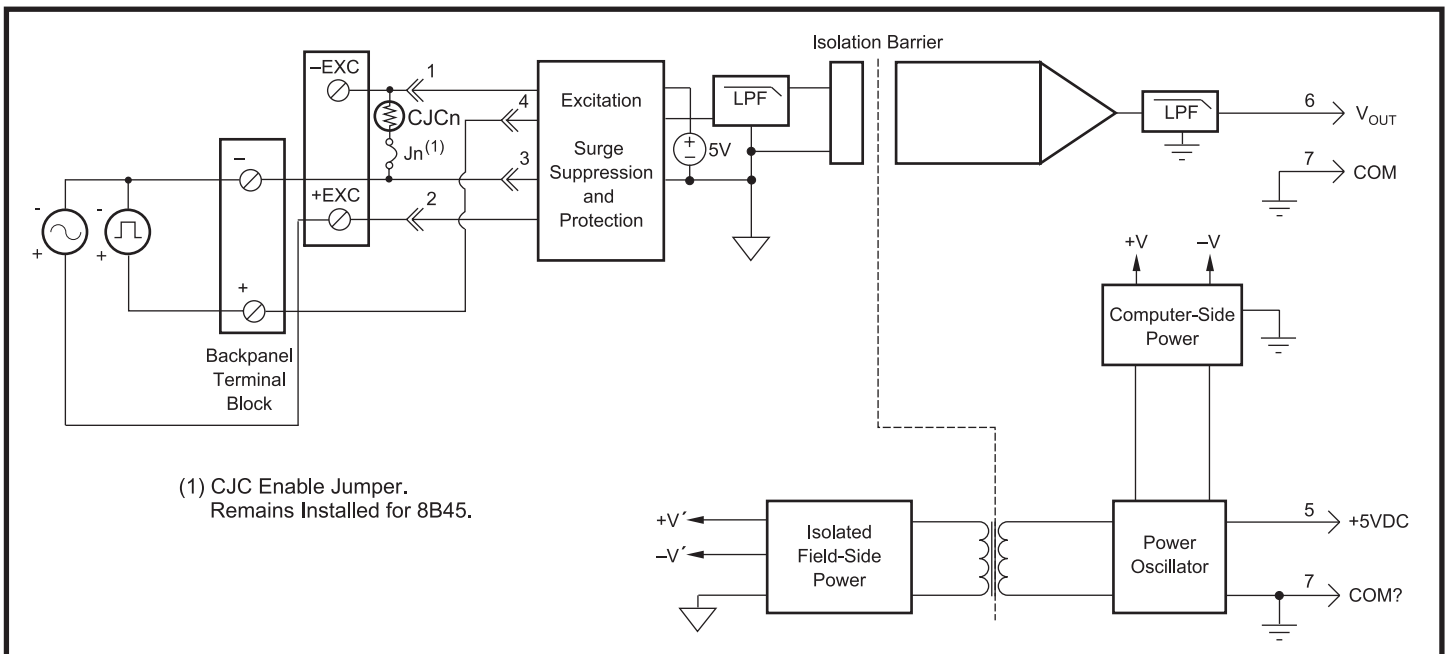

Figure 1: 8B45 Block Diagram

## Specifications Typical at T<sub>A</sub>=+25°C and +5V power

Module	8B45
Input Range	0Hz to 100kHz
Input Threshold	Zero Crossing
Minimum Input	100mVp-p
Maximum Input	350Vp-p TTL, 170Vp-p Zero Crossing
Minimum Pulse Width	4µs
TTL Input Low	0.8V max
TTL Input High	2.4V min
Input Hysteresis	
Zero Crossing	±50mV
TTL	1.5V
Input Resistance	
Normal	68kΩ
Power Off	68kΩ
Overload	68kΩ
Input Protection	
Continuous <sup>(1)</sup>	240Vrms max
Transient	ANSI/IEEE C37.90.1
Excitation	+5V at 8mA max
CMV, Input to Output	
Continuous	1500Vrms max
Transient	ANSI/IEEE C37.90.1
CMR (50 or 60Hz)	100dB
Accuracy <sup>(2)</sup>	±0.05% Span
Linearity	±0.02% Span
Stability	
Offset	±25ppm/°C
Gain	±100ppm/°C
Noise	
Output Ripple	<10mVp-p at Input >2% span
Response Time (0 to 90%)	
8B45-01, -02, -03	160ms, 80ms, 35ms
8B45-04, -05, -06	16ms, 8.5ms, 3.4ms
8B45-07, -08	1.6ms, 0.8ms
Output Range	0 to +5V
Output Protection	Continuous Short to Ground
Transient	ANSI/IEEE C37.90.1
Power Supply Voltage	+5VDC ±5%
Power Supply Current	45mA
Power Supply Sensitivity	±75ppm/%
Mechanical Dimensions (h)(w)(d)	1.11" x 1.65" x 0.40" (28.1mm x 41.9mm x 10.2mm)
Environmental	
Operating Temp. Range	-40°C to +85°C
Storage Temp. Range	-40°C to +85°C
Relative Humidity	0 to 95% Noncondensing
Emissions EN61000-6-4	ISM, Group 1
Radiated, Conducted	Class A
Immunity EN61000-6-2	ISM, Group 1
RF	Performance A ±0.5% Span Error
ESD,EFT	Performance B

### NOTES:

(1) 240VAC between +Input terminal and -Input, +EXC, or -EXC terminals.

120VAC between -Input and +EXC or -EXC terminals.

120VAC between +EXC and -EXC terminals.

(2) Includes linearity, hysteresis and repeatability.

## Ordering Information

Model	Input Range	Output Range
8B45-01	0Hz to 500Hz	0V to +5V
8B45-02	0Hz to 1kHz	0V to +5V
8B45-03	0Hz to 2.5kHz	0V to +5V
8B45-04	0Hz to 5kHz	0V to +5V
8B45-05	0Hz to 10kHz	0V to +5V
8B45-06	0Hz to 25kHz	0V to +5V
8B45-07	0Hz to 50kHz	0V to +5V
8B45-08	0Hz to 100kHz	0V to +5V