



VGA port

DVI-D port

HDMI port

Features

- Meets EIA310c & IEC-3 specification
- 1U, Dual slide rail, 17" or 19" LCD Keyboard drawer
- Built-in 17" LCD monitor, 1280x 1024 resolution
- Option: 19", 1280x 1024 LCD monitor
- USB or PS2 keyboard with touchpad
- Industrial keyboard with touchpad
- Includes a key-locking mechanism to prevent unauthorized access
- Built-in rail self-locking device
- Tempered glass protect LCD screen

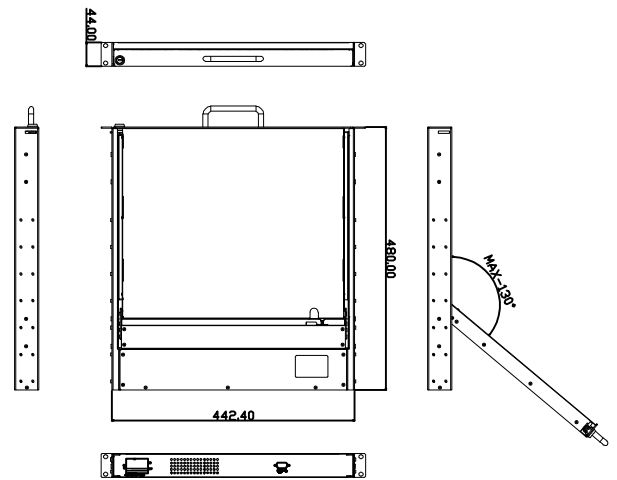

Specification

Model No	AMK701-PB	AMK701-UB
Construction	Heavy-duty steel	
Drawer design	1U, Dual slide rail LCD KB drawer for 19" cabinet Enable independent extraction of LCD or KB alone	
Display	17", 1280x 1024 resolution with tempered glass Option: 19", 1280x 1024 with tempered glass	
Protection	Tempered glass protect LCD screen	
Physical security	Key locking mechanism	
Ports switch	VGA D-sub 15 pin, PS2 keyboard, touchpad	VGA D-sub 15 pin, USB keyboard, touchpad
Keyboard	Industrial keyboard with touchpad Option KB: CH, FR, GR, IT, JP, KR, PT, RU, SP, UK, US	
Power supply	Built-in 60W, 90~264VAC, Operating temp.: -20~70°C	
Power consumption	3 watts stand-by, 25 watts in-use	
Dimension	442.4x 44x 480mm (Wx Hx D)	
Weight	12 kgs	
KVM cable	1.8m PS2 KVM cable	1.8m USB KVM cable

Environmental Factors

	Operating	Non-Operating
Temperature	0°C~50°C	-20°C~60°C
Relative Humidity	10%~90%	10%~95%
Approval	CE, FCC, RoHS	

Ordering Information

AMK701-17PBUS

1U, dual slide rail, 17" LCD, PS2 KB/MS, 1.8m PS2 KVM cable

AMK701-17UBUS

1U, dual slide rail, 17" LCD, USB KB/MS, 1.8m USB KVM cable

AMK701-19PBUS

1U, dual slide rail, 19" LCD, PS2 KB/MS, 1.8m PS2 KVM cable

AMK701-19UBUS

1U, dual slide rail, 19" LCD, USB KB/MS, 1.8m USB KVM cable

Option:

80W, 24~48VDC power supply

±48VDC power supply

Touch screen

DVI-D instead of VGA (D-sub 15-pin)

HDMI instead of VGA (D-sub 15-pin)

Sunlight readable (High brightness)

1.8m, 3.0m, 5.0m KVM cable

Keyboard layout: CH, FR, GR, IT, JP, KR, PT, RU, SP, UK, US