

# W15IE3S-PTA3

## 15.6" Intel® Celeron® N6211 PT Series HMI Touch Panel PC



### KEY FEATURES

- Low power consumption with Intel® Celeron® Elkhart Lake N6211 processor
- Fanless cooling system and ultra-low power consumption
- Front IP65 for protection against water and dust
- A true flat, easy-to-clean front surface with edge-to-edge design



### SPECIFICATIONS

Display			
<b>Touch / Glass</b>	Projected Capacitive Multi Touch Screen	<b>Resolution</b>	1920x1080
<b>Size</b>	15.6 inches	<b>Contrast Ratio</b>	800:1
<b>Panel Brightness</b>	400.0 nits	<b>View Angles</b>	85,85,85,85
<b>Active Area</b>	344.16x193.59 mm		
System Specification			
<b>WLAN</b>	Support (Optional)	<b>BT</b>	Support (Optional)
<b>Processor</b>	Intel® Celeron® N6211 ( up to 3.0GHz) Intel® Celeron® N6210 (up to 2.6GHz) (Optional)	<b>Memory</b>	1 x SO-DIMM, DDR4 3200 MHz, 4GB 8GB (Optional) 16GB (Optional)
<b>Storage</b>	1 x M.2 2242 B-key SSD 128GB M.2 2242 B-key SSD up to 512GB (Optional) 1 x SATA III for 2.5" SSD/HDD up to 1TB (Optional)	<b>Ethernet controller</b>	2 x Intel® Ethernet Controller
<b>Security</b>	TPM 2.0	<b>Operating System</b>	Windows 11 IoT Enterprise (64 bit) (Optional) Windows 11 Pro 64 bit (Optional) Windows 10 IoT Enterprise (64 bit) (Optional) Linux Ubuntu 22.04 (Optional)
Environment			
<b>Operating Humidity</b>	10% to 90% RH, Non-Condensing	<b>Operating Temperature</b>	0°C to 50°C
<b>Storage Temperature</b>	-10°C to 60°C	<b>IP rating</b>	Front IP65
Certification			
<b>Certification</b>	CE, FCC		
Mechanical			
<b>Dimension</b>	388 x 233 x 40 mm	<b>Mounting</b>	VESA Mount
<b>Enclosure</b>	Plastic	<b>Cooling System</b>	Fanless Design
IO Ports			
<b>USB Port</b>	2 x USB3.2 Gen1x1 (Type-A)	<b>Serial Port</b>	1 x RS232(Default)/422/485
<b>Video</b>	1 x HDMI 2.0 (Optional)	<b>Audio</b>	2 x Speaker (Optional)
<b>LAN</b>	2 x RJ45-10/100/1000 Mbps	<b>Indicator</b>	Power LED Indicator
Power			

Power Rating 12V DC

**Control**

Button 1 x Power Button  
1 x Reset Button

**Accessory**

Accessory Quick Start Guide(Hardcopy)  
AC Adapter 12V/50W  
Power Cord

**DIMENSIONS** UNIT:MM

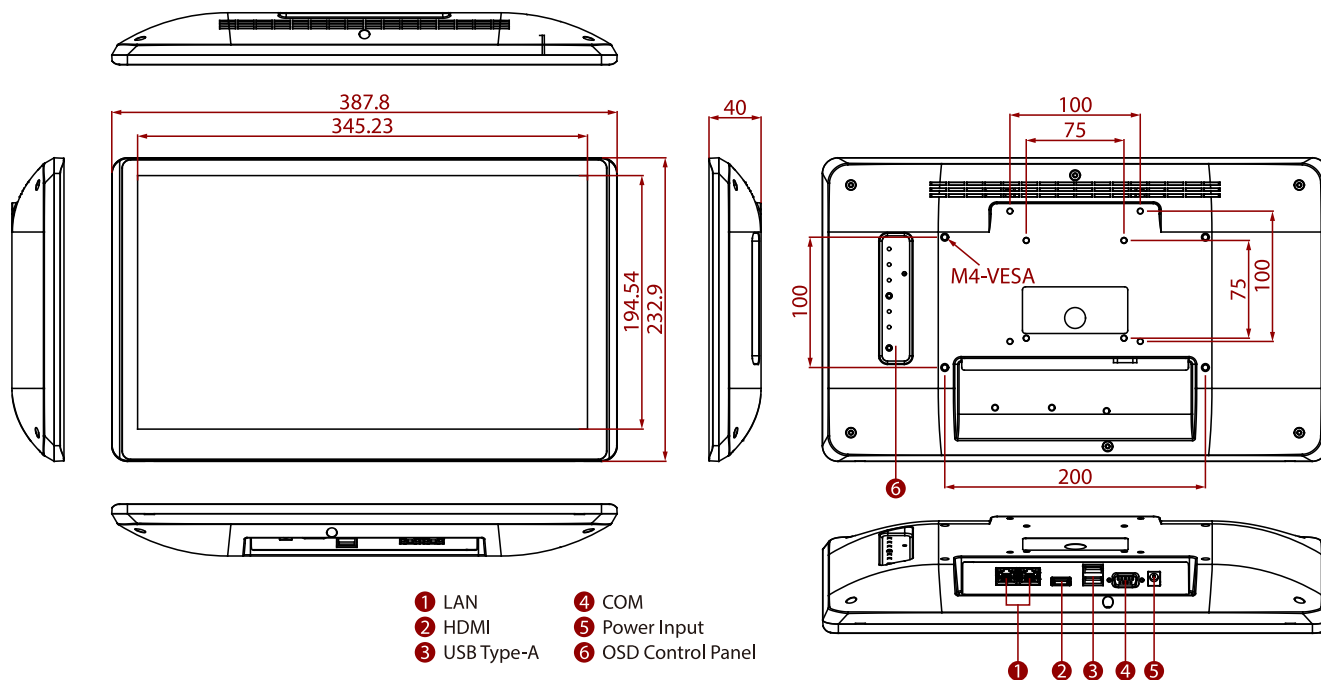

**NOTE**

- 1.This is a simplified drawing and some components are not marked in detail.
- 2.Please contact our sales representative if you need further product information.
- 3.All specifications are subject to change without prior notice.
- 4.The product shown in this datasheet is a standard model.For diagrams that contain customized or optional I/ O, please contact the Winmate Sales Team for more information.